



# INSTRUCTIONS FOR OPERATION AND CARE XVGA GRATER/SHREDDER AND XVSA SLICER ATTACHMENTS



Our versatile grater/shredder attachments can be used to grate and shred cheeses, raw vegetables, nuts, breadcrumbs, etc. depending on the plate selected. Our S/S plates are available with 3/32", 3/16", 1/4", 5/16" or 1/2" size holes and a special grating plate for breadcrumbs & hard cheeses. A plate holder with shaft and one 3/16" plate are included with the XVGA attachment.

Our slicer attachments can be used for slicing potatoes (from 1/16" to 5/8" thickness); cutting vegetables for salads and coleslaw; or for slicing fruits and nuts. An adjustable slicer plate with shaft are included with the XVSA attachment.

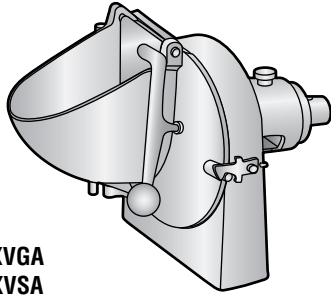

XVGA  
XVSA

## WARNING

*There are sharp rotating knives behind the front door; keep hands out of hopper and use a feed pusher or stomper to push product into the hopper – do not use your fingers. Always stop power unit before opening front for changing, cleaning, or servicing anything on this unit. Only trained and qualified persons 18 years and older should use these attachments.*

These attachments are made up of the following four basic components:

1. XVSH Housing
2. XVSD Front Door or Hopper
3. XVSP Pusher Plate
4. Plate Holder or Adjustable Slicer Plate units
  1. Adjustable Slicer Shaft XASP with S/S "S" knife
  2. Shredder Plate Holder XPH

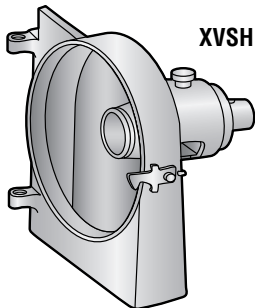

XVSH

### HOUSING OR BACK CASE

The housing or back case mounts into the attachment socket of a mixer, food cutter or power drive unit and is retained by the pointed thumbscrew that goes through the attachment hole into the indentation on the neck of the machine.

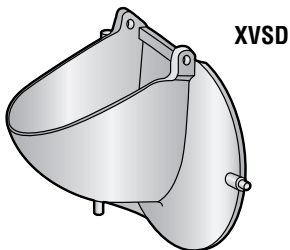

XVSD

### DOOR OR HOPPER

The front door is a hopper and lever feed design. It hinges onto the back case and is held closed with an adjustable latch. To remove the front door, lift the latch and swing the door open while lifting it from the hinge holes.

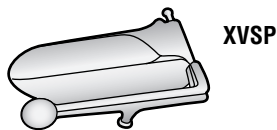

XVSP

### PUSHER PLATE

The pusher plate has an integrated handle to push the food into the rotating disc or slicer knife. It has pins at both ends of the top and hinges into the front door. The pusher plate has a rubber-tipped stop screw (XP1018) under the handle that can be adjusted to prevent the plate from coming in contact with the plate or blade.

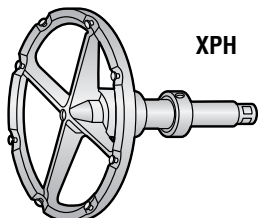

XPH

### PLATE HOLDER WITH SHAFT

Shredder plates are available with 3/32", 3/16", 1/4", 5/16" or 1/2" hole sizes. These plates have keyhole slots for attaching to shouldered studs on the plate hubs.



## TO INSTALL SHREDDER OR GRATER DISCS

Stop the machine. Orient the plate with the cutting edge away from the shaft assembly. Locate the keyhole slots on the plate and slide the wide part of the slots over the studs on the plate holder. When the plate is flush with the holder, rotate it clockwise to lock it in position. It is possible to loosely assemble the plate to the hub (sharp edge out), then place it on a work surface (the teeth on the plate will mar a finished table). Press down and turn the hub until plate locks into place. The sharp "teeth" should face out on the holder. To detach the plate from the hub, reverse the installation procedure. A safe method is to use protective gloves and press the palm of one hand against the plate to rotate it.

**Note:** The plates are slightly bent to provide holding pressure when in position.

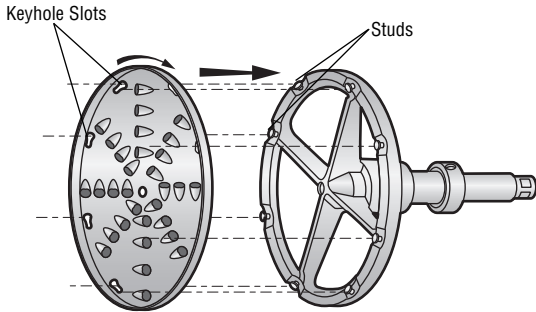

### SHREDDER PLATE

The coarse plates are normally used for making chopped slaw, cutting vegetables for soup stock, salad blends or "hash brown" potatoes. The medium and finer plates are for fine shredding of carrots, beets, turnips, etc., and for salads. See our application chart at the end of these instructions.

### GRATER PLATE

The grater plate may be used for crumbling hard cheese or grating hard vegetables.

## TO INSTALL XPH PLATE HOLDER ASSEMBLY

Stop the machine. With door open, pull the locking pin XP1007 up and insert XPH until the square end of the shaft fits snugly into the power unit. Then release the locking pin to hold the XPH in proper position.

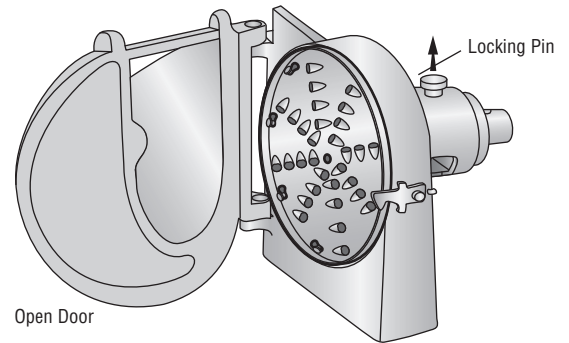

## ADJUSTABLE SLICER PLATE ASSEMBLY & INSTALLATION

Turn off and unplug the machine. Adjust the slicing thickness from approximately 1/16" to 5/8" by turning the gray plastic adjusting nut XP1022. Lift the silver locking pin XP1007 on the top of the rear of the housing and open the front door and slide the slicer unit back into operating position. The square end of the shaft may have to be manually rotated to seat into the machine socket properly. Secure the unit to the machine by tightening the pointed thumbscrew in the hole on the top side of the attachment hub. Attach the pusher plate XVSP and close and latch the door XVSD before turning the machine on.

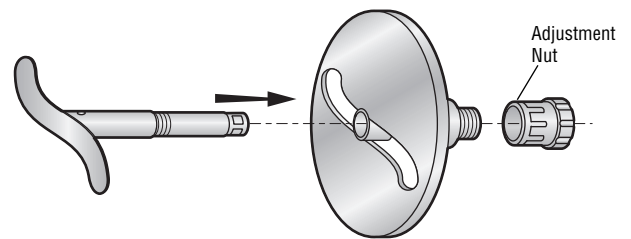

### TO ADJUST THICKNESS OF SLICES

Stop the machine. While you can adjust the thickness of slices with Adjustable Slicer Plate Assembly in position, by turning the gray plastic Adjusting Knob XP1022, accessed through the opening in the rear housing, we recommend that you remove the Adjustable Slicer Plate Assembly from the housing and turn the Adjusting Knob while carefully holding the plate.

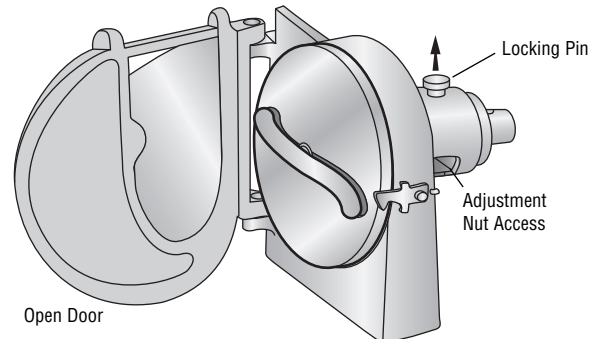

**CAUTION:** The adjusting nut turns with the shaft and adjustments should not be attempted unless the power unit is turned off and unplugged.





### TO REMOVE XASP ADJUSTABLE SLICE PLATE ASSEMBLY FROM HOUSING

Open the door all the way and raise the locking pin XP1007 (on top of rear of housing) and the assembly will be free for removal by pulling outward.

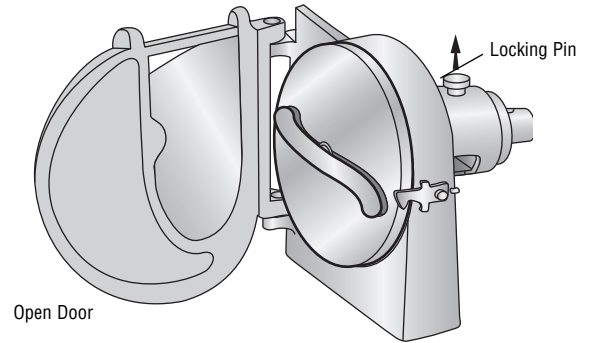

### TO REMOVE ATTACHMENT FROM POWER UNIT

Loosen thumbscrew on power unit until hub is free for removal from unit.

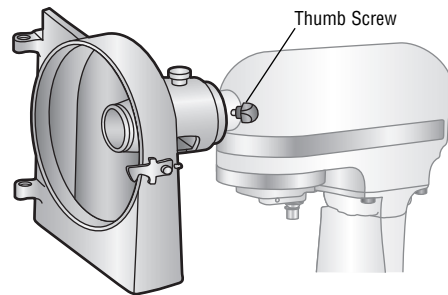

### PUSHER PLATE REMOVAL

Raise the Pusher Plate and slide it out of the slot in the door XVSD.

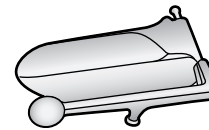

## OPERATION

1. Stop the power unit (mixer, food cutter, chopper, power drive etc.)
2. Attach the housing of slicer to the attachment socket of the companion machine with the thumbscrew.

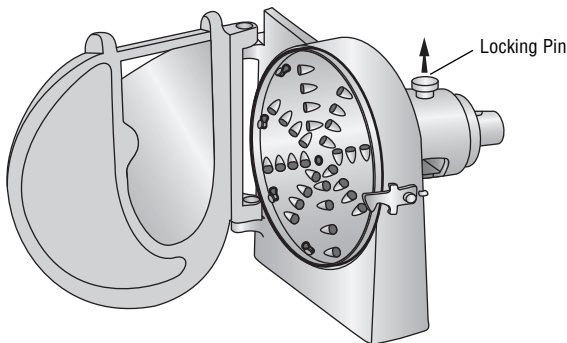
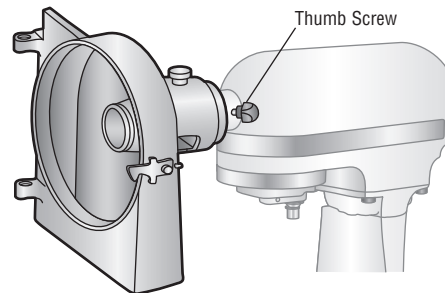

3. Select the grater/shredder or slicer assembly to be used. Lift the locking pin and insert the plate and shaft assembly into the drive position. Release the locking pin. Set the slice adjustment (if used) to the proper thickness.

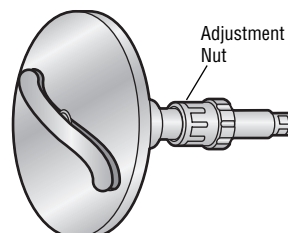



- Drop the hinge pins of the front door into the holes in the housing.

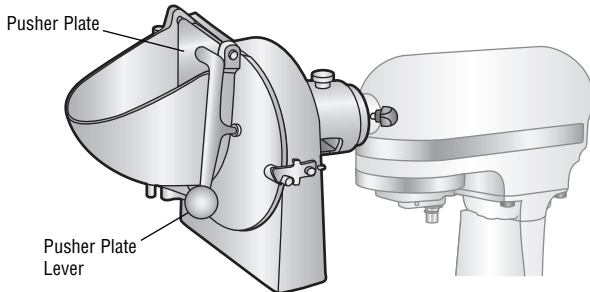
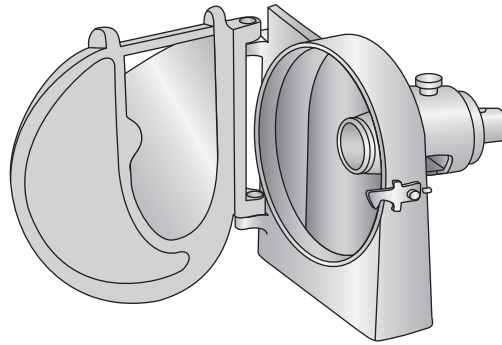

- Close the slicer front door and fasten the latch.
- Start the machine. Set at a speed to produce the best product (see machine manual)
- Raise the pusher plate lever.
- Place the food to be sliced in the hopper and gently press down on the pusher plate lever.

**CAUTION: Keep Hands out of Hopper – use a stomper or food pusher.**

**Note:** Too much pressure crushes the food and causes irregularity in the slices. Large items may have to be cut down to fit into the hopper.

## MAINTENANCE INSTRUCTIONS

### CLEANING

- Stop the power unit (mixer, food cutter, power drive, etc.).
- Release the latch and remove the front door.
- Lift the locking pin and withdraw the shredding or slicing unit from the housing.

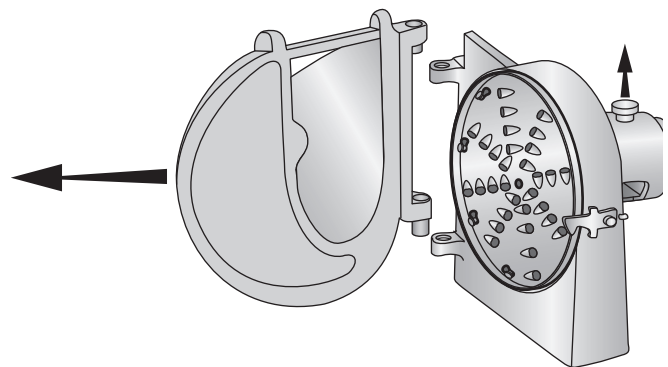
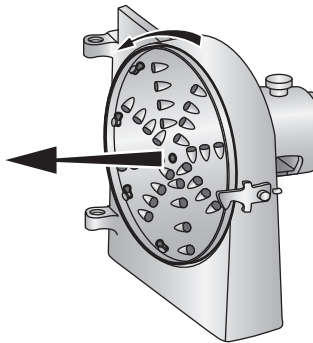

- The shredder and grater plates can be easily removed from the plate hub by rotating plate counter-clockwise to release the keyhole slot from the studs.

**CAUTION: These plates are sharp and must be handled with care.**

- All components of these attachments may be cleaned by HAND WASHING ONLY, using mild detergent in warm water. These units are NOT DISHWASHER SAFE due to the corrosive nature of commercial detergents, which can discolor aluminum and turn it black. Rinse in hot, clear water and dry immediately. It is important that juices be cleaned from the attachments before they dry.

**Note:** Frequent lubrication with a USDA approved grease is necessary to prevent shaft seizing.



6. When using the adjustable slicer plate, make sure it is cleaned frequently to assure easy thickness adjustment. Occasionally disassemble the slicer plate for a thorough cleaning. To do this it is necessary to unscrew the knurled thrust bearing, which has a left hand thread, to release the spring. Withdraw the knife and shaft assembly. Unscrew the adjusting nut from the plate. Use a drop of approved food machinery oil on the shaft and adjustment threads after cleaning.

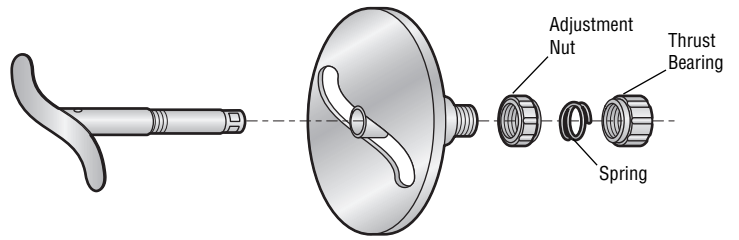

**Note:** After cleaning, to prevent damage the thrust bearing must be tightened until sealed against shoulder on shaft. Failure to properly reassemble can result in damage to knives, shaft and slicer plate. Do not clean any of these components in a dishwasher with strong detergents or chemicals. Use a USDA approved grease on the shaft for best operation.

**CAUTION:** Do not permit water or moisture to remain on or in the hub, shaft, or the rear opening in the housing. This condition will result in rusting which will eventually destroy the rear end components and shaft and void the factory warranty.

### KNIFE SHARPENING

Occasional touching up along the edges of the knife with a honing stone will keep cutting operations at peak performance.

### PUSHER PLATE STOP

Frequently check that the pusher plate does not hit the grater plate holder or knife shaft assembly. The Pusher Plate Stop XP1018 can be adjusted to avoid touching the internal moving parts. With proper care and maintenance, your Vegetable Grater/Shredder/Slicer Attachment will provide you with many years of performance.

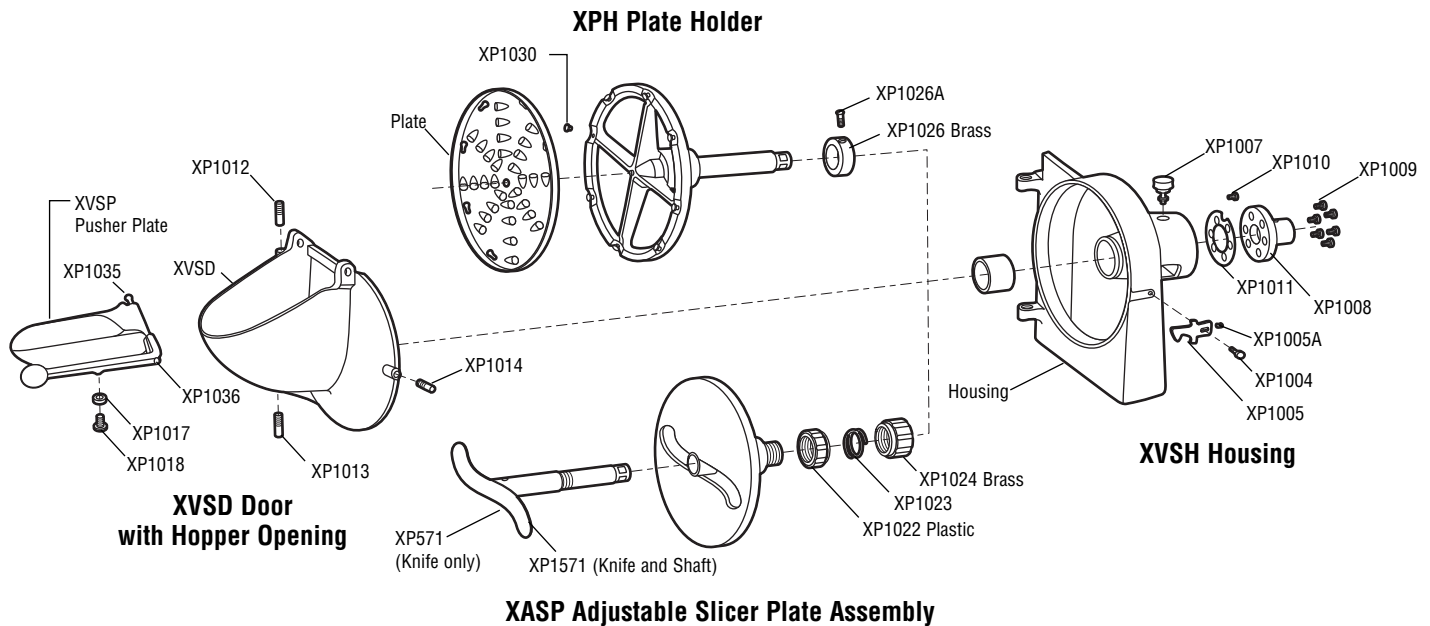

## WARNING



**KEEP FINGERS AND HANDS AWAY FROM MOVING PARTS**



## PART NUMBER LISTING

### XVSH HOUSING

XVSH	Housing size 12
XP1004	Threaded (Hex) Pin for housing latch
XP1005	Latch with setscrew
XP1005A	Latch setscrew only
XP1007	Shaft Lock knob - top
XP1008	Housing Hub with locating pin – six holes
XP1009	Flat Head Machine Screw (6) for hub
XP1010	Knife Lock Screw
XP1011	Fiber gasket

### XPH PLATE HOLDER

XPH	Plate Holder Assembly Complete
XP1026	Brass Collar with set screw
XP1026A	Set Screw for Collar
XP1030	Stud for Plate Holders
XSP332	3/32" S/S Shredder Plate
XSP316	3/16" S/S Shredder Plate
XSP14	1/4" S/S Shredder Plate
XSP516	5/16" S/S Shredder Plate
XSP12	1/2" S/S Shredder Plate
XGP	S/S Grater Plate

### XASP ADJUSTABLE SLICER PLATE

XP571	"S" Knife only
XP1571	"S" Knife and Shaft Assembly
XP1022	Knife Adjusting Nut- Gray Plastic
XP1023	Tension Spring
XP1024	Bronze Lock Nut or Thrust Bearing

### XVSD DOOR

XP1012	Upper Hinge Pin (long)
XP1013	Lower Hinge Pin (short)
XP1014	Latch Pin

### XVSP PUSHER PLATE

XP1017	Stop Nut
XP1018	Stop Screw
XP1035	Ball End Hinge Pin
XP1036	Hinge Pin

## Shredder and Grater Plate Hole Sizes with Typical Applications

Food Product	1/2" Shredder Plate 000	5/16" Shredder Plate 0	3/16" Shredder Plate 3	3/32" Shredder Plate 7	Universal Grater Plate 14
Cole Slaw	●	●			
Bread Crumbs		●			●
Cheese		●			
Soft Cheese For Pizza			●		
Carrots For Coloring			●	●	
Cheese For Tacos				●	
Hard Cheese					●

Stainless steel Shredder Plate hole sizes (not drawn to scale)

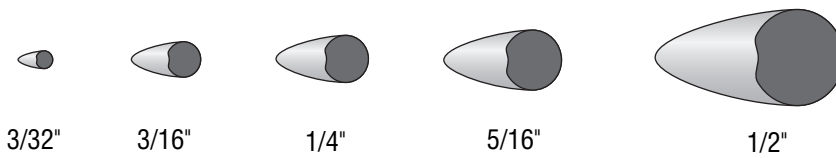

SS Grater Plate



**For *Hard* Cheese only**



### WARNING

KEEP FINGERS AND HANDS  
AWAY FROM MOVING PARTS

## LIMITED XVSA/XVGA ATTACHMENT WARRANTY

Globe Food Equipment Company ("GFE") warrants to the original purchaser of new equipment that said equipment, when installed in accordance with our instructions within North America and subjected to normal use, is free from defects in material or workmanship for a period of 1 year from invoice date. The XVSA Vegetable Slicing Attachment and XVGA Shredder/Grater Attachment have a 1-year replacement warranty. There is no labor warranty for mixer attachments.

THIS WARRANTY IS IN LIEU OF ALL OTHER WARRANTIES, WHETHER EXPRESS OR IMPLIED. GFE EXPRESSLY DISCLAIMS ANY IMPLIED WARRANTY OF MERCHANTABILITY OR EXPRESS OR IMPLIED WARRANTY OF FITNESS FOR A PARTICULAR PURPOSE.

GFE'S OBLIGATION AND LIABILITY UNDER THIS WARRANTY IS EXPRESSLY LIMITED TO REPAIRING AND REPLACING EQUIPMENT WHICH PROVES TO BE DEFECTIVE IN MATERIAL OR WORKMANSHIP WITHIN THE APPLICABLE WARRANTY PERIOD. All repairs pursuant to this Warranty will be performed by an Authorized Designated GFE Service Location during normal working hours. IN NO EVENT SHALL GFE BE LIABLE FOR INCIDENTAL OR CONSEQUENTIAL DAMAGES TO BUYER OR ANY THIRD PARTY, INCLUDING, WITHOUT LIMITATION, LOSS OF PROPERTY, PERSONAL INJURY, LOSS OF BUSINESS OR PROFITS OR OTHER ECONOMIC LOSSES, OR STATUTORY OR EXEMPLARY DAMAGES, WHETHER IN NEGLIGENCE, WARRANTY, STRICT LIABILITY, OR OTHERWISE.

This Warranty is given only to the first purchaser from a retail dealer. No warranty is given to subsequent transferees.

This Warranty does not cover product failures caused by: failure to maintain, neglect, abuse, damage due to excess water, fire, normal wear, improper set up and use. Periodic maintenance is not covered.

THE FOREGOING WARRANTY PROVISIONS ARE A COMPLETE AND EXCLUSIVE STATEMENT BETWEEN THE BUYER AND SELLER. GFE NEITHER ASSUMES NOR AUTHORIZES ANY PERSONS TO ASSUME FOR IT ANY OTHER OBLIGATION OR LIABILITY IN CONNECTION WITH SAID EQUIPMENT.

Example of items not covered under warranty, but not limited to just these items:

1. Acts of God, fire, water damage, vandalism, accident, theft.
2. Freight damage.
3. Improper installation or alteration of equipment.
4. Use of generic or after market parts.
5. Repairs made by anyone other than a GFE designated servicer.
6. Lubrication.
7. Expendable wear parts – shredder/grater plates and "S" knife.
8. Cleaning of equipment.
9. Misuse or abuse.

### **FOR COMPLETE XVSA, XVGA AND SHREDDER PLATE SALES**

**TOLL FREE: 1-800-347-5423    FAX: 937-299-4147**

### **FOR SPARE PARTS SALES:**

**TOLL FREE: 1-800-745-6238    FAX: 937-290-0585**

**GLOBE FOOD EQUIPMENT COMPANY  
PO BOX 3209 DAYTON, OHIO 45439  
[www.globeslicers.com](http://www.globeslicers.com)**

