

Project

Item #

Quantity



GLOBE FOOD EQUIPMENT COMPANY

60 Quart Pizza Mixer

SP62P



# SP62P 60 Quart Pizza Mixer

### Model

- SP62P - 60 Quart Pizza Mixer

*Built into each mixer is the quality of workmanship and design synonymous with Globe.*

### Standard Features

- Powerful 3 HP custom built motor
- Two fixed speeds
- High torque direct gear drive transmission
- Oil bath transmission
- Heat-treated hardened steel alloy gears and shafts
- Thermal overload protection
- Power bowl lift
- Automatic safety shut off provides superior motor and transmission protection
- Rigid cast iron body
- Capacity: up to 50 lbs. of flour (75 lb. batch size)
- Stainless steel bowl guard with built in ingredient chute
- NSF approved enamel gray paint
- Front mounted controls
- 15 minute timer
- Industry standard #12 attachment hub
- Safety interlocked bowl guard and bowl lift
- Non-slip rubber feet



### Standard Accessories

- 60 quart stainless steel bowl
- Spiral dough hook (aluminum)
- Bowl truck

### Optional Attachments/Accessories

- Slicer/shredder/grater for #12 hub
- Meat grinder for #12 hub

### Standard Warranty

- Two-years parts and one-year labor

Approved By: \_\_\_\_\_

Date: \_\_\_\_\_



**GLOBE FOOD EQUIPMENT COMPANY**

[www.globeslicers.com](http://www.globeslicers.com)

2153 Dryden Rd.  
Dayton, OH 45439  
Phone: 937-299-5493  
Phone: 800-347-5423  
Fax: 937-299-4147



# 60 Quart Pizza Mixer

# SP62P

## Specifications

**Motor:** 3 HP, grease packed ball bearing, air cooled, 220/60/1, 16 amps or 208/60/3, 12 amps. Thermal overload protection (automatic reset).

**Power Bowl Lift:** 1/8 HP motor. Raises and lowers the bowl as well as locking it in place at the top and bottom positions.

**Construction/Finish:** Rigid cast iron base, column and head. NSF approved enamel gray paint.

**Capacity:** 60 quart (56.8 liter) bowl.

**Transmission:** Direct drive, fixed speed transmission is made of heat treated, hardened alloy, precision milled gears that operate the planetary action and provide high torque mixing power. The gears are continuously lubricated in an oil bath and all shafts are mounted in ball bearings.

**Automatic Safety Shut Off:** If speeds are changed during operation the mixer will automatically shut down to prevent damage being done to the motor or transmission.

**Safety Interlocks:** The bowl guard and power bowl lift are interlocked. The mixer will automatically shut down when the guard is opened or the bowl is lowered.

**Cord:** 6 foot cable, hard wired.

### Agitator Speeds (RPMs):

First 72  
Second 116

### Attachment Speeds (RPMs):

First 234  
Second 410

**Standard Equipment:** Standard equipment includes a 60 quart #304 series stainless steel bowl, aluminum spiral dough hook, stainless steel bowl guard with built in ingredient chute, 15 minute timer, bowl truck and #12 attachment hub.

### Shipping Information:

Freight Class: 85  
Net Weight: 980 lbs. (444 kg)  
Shipping Weight: 1,228lbs. (556 kg)  
Shipping Dimensions: 48"W x 48"D x 76"H (121.9cm x 121.9cm x 193cm)  
Cartons are affixed to a skid (pallet). The weight and dimensions of this skid are included above and may vary from shipment to shipment.

### Dimensions:

Foot Print = 29.1" x 35"  
(74cm x 89cm)  
Overall Length = 38.6" (98cm)  
Overall Width = 29.1" (74cm)  
Overall Height = 59.8" (152cm)

### Optional Attachments:

**XMCA-SS Meat Grinder Assembly** (Polished stainless steel cylinder, worm gear, ring, and pan. Includes knife, 3/16" plate, stainless steel pan, and pusher.)

### Chopper Plate Sizes Available:

- CP02-12** 1/16" (2mm)
- CP04-12** 5/32" (4mm)
- CP05-12** 3/16" (5mm)
- CP06-12** 1/4" (6mm)
- CP08-12** 5/16" (8mm)
- CP10-12** 3/8" (10mm)
- CP12-12** 1/2" (12mm)
- CP14-12** 9/16" (14mm)
- CP16-12** 5/8" (16mm)
- CP18-12** 11/16" (18mm)
- CP00-12** Stuffing Plate
- XST12** 1/2" stuffing tube (sheep)
- XST34** 3/4" stuffing tube (hog)

**XVSGH** 9" Slicer/Shredder/Grater Housing Only (*no plates included - must select from plates below*)

**XASP** Adjustable slicing plate  
**XPH** Plate holder - \*only 1 required

### Shredding/Grating Plates:

- XSP332\*** 3/32" (2.3mm)
- XSP316\*** 3/16" (4.7mm)
- XSP14\*** 1/4" (6.3mm)
- XSP516\*** 5/16" (7.9mm)
- XSP12\*** 1/2" (12.7mm)
- XGP\*** Grating plate

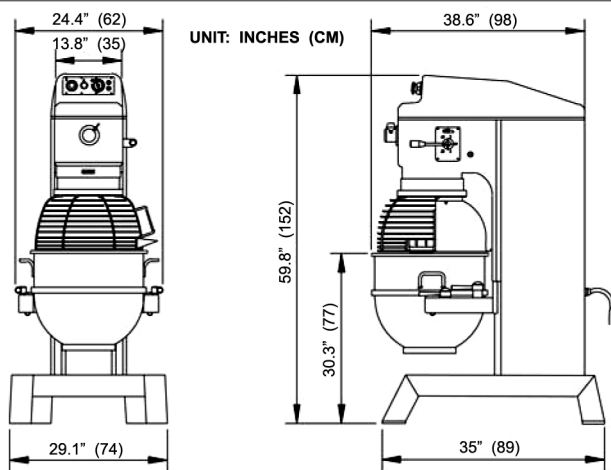

## GLOBE FOOD EQUIPMENT COMPANY

[www.globeslicers.com](http://www.globeslicers.com)

2153 Dryden Rd.  
Dayton, OH 45439  
Phone: 937-299-5493  
Phone: 800-347-5423  
Fax: 937-299-4147

Printed In U.S.A. 04-2010

Specifications are subject to change without notice.